

triton Biscuit Joiner BJA 300

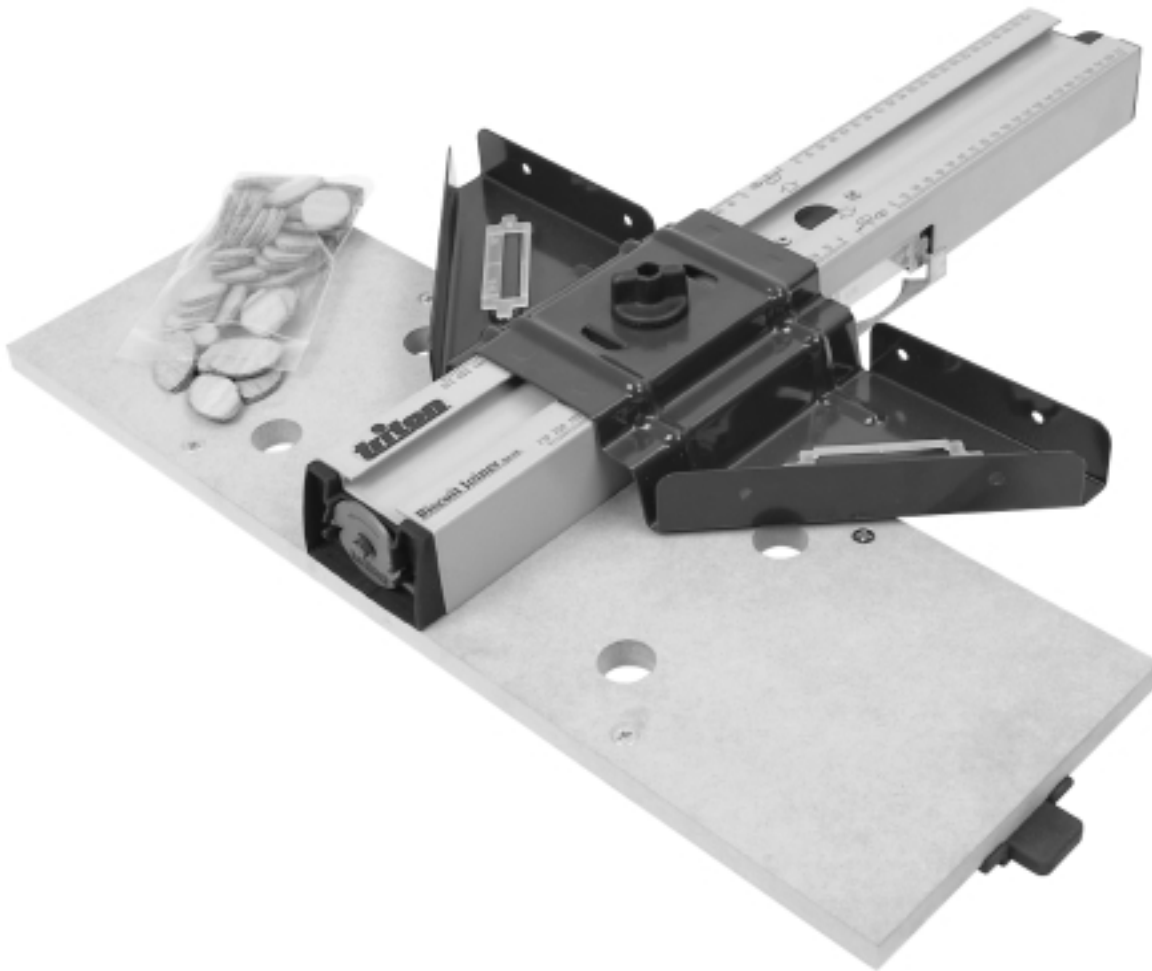

Assembly & Operating Instructions

Thank you for purchasing the Triton Biscuit Joiner - BJA300. You now have a versatile and accurate timber joining system which should give you years of trouble-free service.

Please take the time to read these instructions, and pay attention to all safety warnings.

This Biscuit Joiner suits Triton Router Table - RTA 300 only, mounted to either a Triton Workcentre or a Triton Router Stand. The cutter supplied has a $\frac{1}{2}$ " (12.7mm) shank. An additional $\frac{1}{4}$ " (6.35mm) shank is also supplied for use in smaller routers.

Tools required: Philips-head screwdriver, 10mm spanner, ruler

	Page		Page
ASSEMBLY	2	Bevel Joints	5
Dust Extraction	3	Cutting Two-up	5
Power Connection Warning	4	Multiple Biscuit Joints	6
Safety	4	Inset Joints	6
OPERATION	4	Make a Work Steady	6
Cutter Height Adjustment	4	Mid-panel Joinery	7
Sighting Up Cuts	4	Biscuit Spacing	7
Right-angle Butt Joint	4	Test Assembly	7
End-to-end Butt Joint	4	REPLACEMENT BISCUITS	8
45° Mitre Joint	4	GLUES AND GLUE APPLICATION	8
Edge-to-edge Joints	4	CARE OF THE CUTTER	8
Edge-to-face Panel Joints	5		

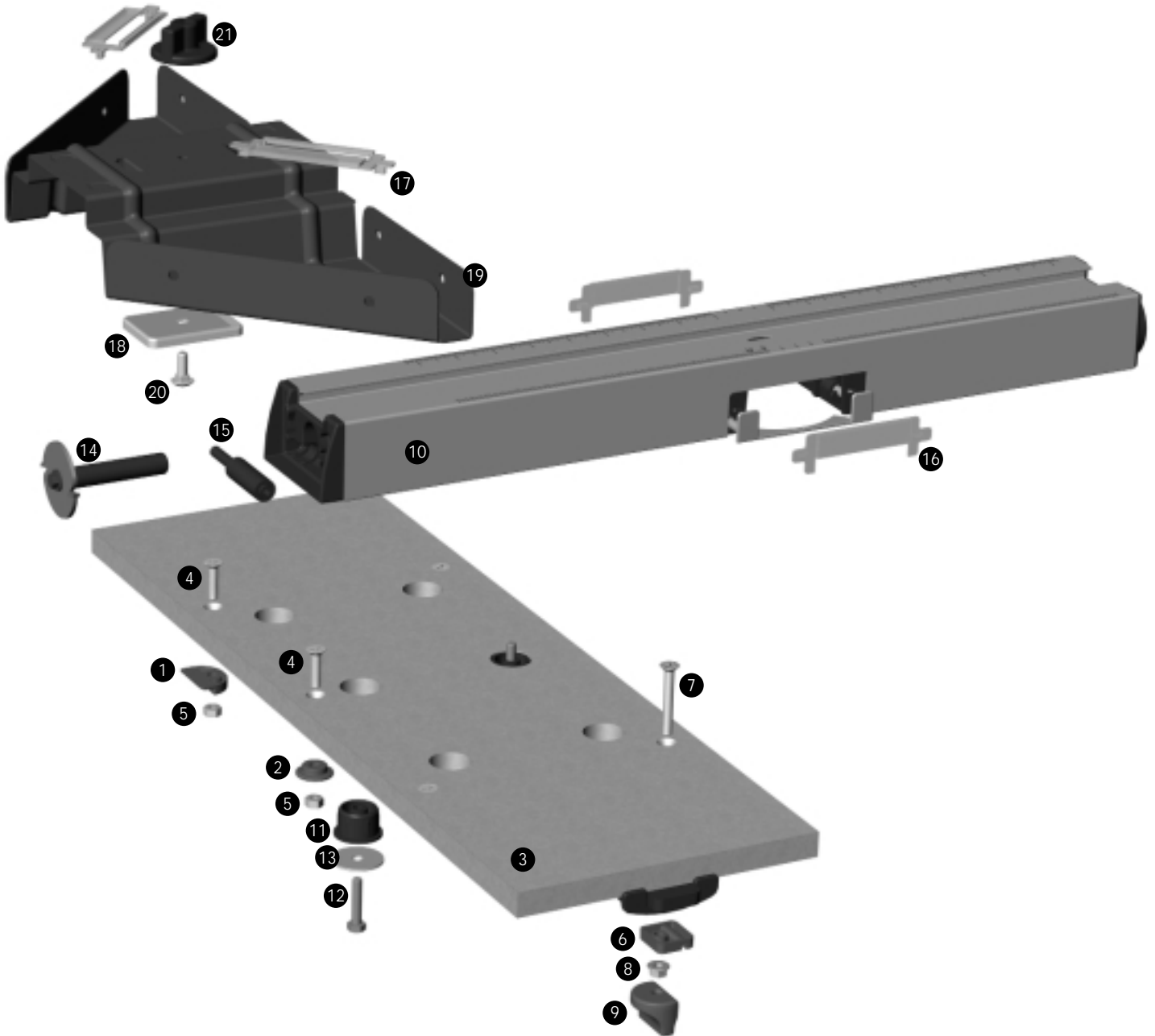

COMPONENTS LIST

Fastener Bag Contents

- ① Outer Bearing x 2
- ② Hold-down x 1
- ④ M6 x 20 Screw x 3
- ⑤ M6 Hex Nut x 3
- ⑥ Inner Bearing x 2
- ⑦ M6 x 45 Screw x 2
- ⑧ M6 Flange Nut x 2
- ⑨ Inner Clamp Knob x 2
- ⑪ Boss x 2
- ⑫ M6 x 30 Hex Bolt x 2
- ⑬ Washer x 2
- ⑱ Sliding Guide Clamp
- ⑳ Coach Bolt x 1
- ㉑ Round Knob with M6 nut x 1

- ③ Sliding Insert x 1
- ⑩ Main Body x 1
- ⑭ † Biscuit Joiner Cutter on 1/2" Shank x 1
- ⑮ † 1/4" Shank x 1
- ⑯ † Notched Windows x 2
- ⑰ † Slotted Windows x 2
- ⑲ Sliding Guide x 1
- Pack of 50 Biscuits x 1

† Supplied fitted in position

ASSEMBLY

Step 1: Fit the Outer Bearings (1) and Hold-down (2) to the Sliding Insert (3) using the M6 x 20 Screws (4) and M6 Hex Nuts (5) as shown. Fit the Inner Bearings (6) to the sliding insert using the M6 x 45 Screws (7) and M6 Flange Nuts (8). Do not yet tighten. All bearings should be parallel to the sides of the sliding insert.

Fit the Bosses (11) from underneath the two central holes in the sliding insert and attach the Main Body (10) to the sliding insert by tightening the M6 x 30 Hex Bolts (12) & Washers (13) through the captive nuts in the main body.

Loosen off the depth stop screws on the underneath of the sliding insert to allow approximately 29mm movement of the spring-loaded plunger. (Fig. 4)

Step 2:

Slide the zinc locking pin on the underside of the main body to the central "lock" position.

Fit the sliding insert into the router table tracks by hooking the hold-down under the outer (orange) track first. The slots on the inner bearings should locate onto the flange on the aluminium inner track. Now firmly tighten the inner bearing screws and check that the sliding insert slides smoothly. If there is any float between the aluminium inner track and the inner bearings, loosen the screws, twist the bearing slightly and re-tighten.

The lock pin on the main body should locate in the slot on the router plate. **In Use:** When a safety guard is depressed the lock pin is released, allowing the fence to slide in the direction the guard is depressed. The fence will automatically spring back to its central position.

Screw the Inner Clamp Knobs (9) onto the inner bearing screws, they cut their own thread. **In use:** When fitting or removing the sliding insert the cut-away edges of the clamps must face away from the inner track. During operation turn the cut away edges toward the inner track. Do not over-tighten, the sliding insert should be held down yet free to slide.

Check that the Biscuit Joiner is level with or slightly above the table surface and if necessary remove it and adjust the height of the aluminium inner track on the router table.

Step 4: Remove the Biscuit Joiner Cutter (14) from its storage position in the end of the main body.

If you have a 1/4" (6.35mm) router, remove the 1/4" Shank (15) from its storage position in the end of the main body. If tight, gently prise it out using a screwdriver. Unbolt the cutting disc from the 1/2" shank and refit it to the 1/4" shank. Do not overtighten. Store the unused 1/2" shank in place of the 1/4" shank in the end of the main body.

Remove the Biscuit Joiner from the table. Fit the large insert ring, supplied with the router table, to the router plate. Tighten the cutter firmly into your router collet.

Adjust the cutter height so that there is 5-7mm (3/16" - 3/8") clearance between the underside of the cutter and the router plate. Make sure the router's height adjustment is securely locked before use.

Step 5: Familiarise yourself with the two sets of Windows (16 & 17). They reduce the risk of finger entry into the cutter zone, and improve saw dust extraction. The windows are reversible so that the two sets cover the full range of cutter height adjustment from 5mm to 25mm (3/16" to 1") above the table. The cutter should never be set any higher than 25mm (1") above the router plate. (Fig. 1)

To remove the windows push outwards, from the inside, near each side of the window. They are quite tight when new, but loosen up with use.

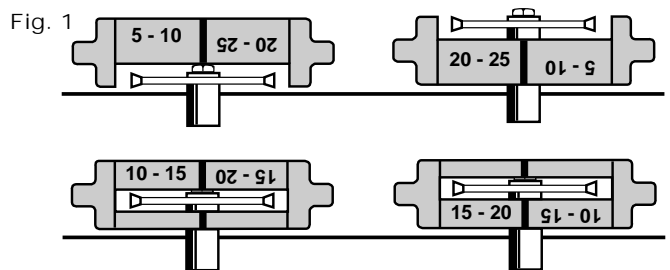

When re-fitting, use the safety guards to push them fully home. Store the unused pair of windows in the holes provided on the sliding guide.

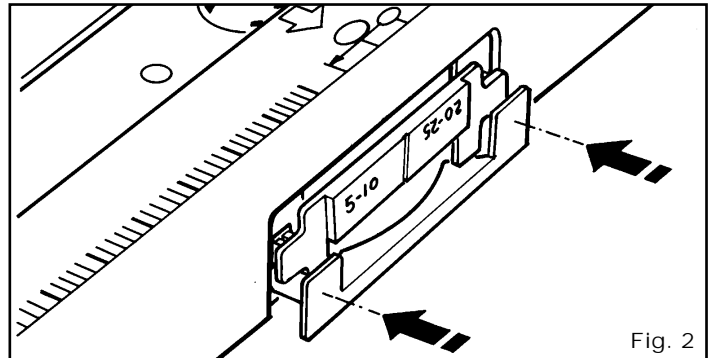

For the next few steps, fit the notched windows (with the "5-10" designation reading right way up) to both sides of the main body by inserting them into the slots beside each window opening. Use the safety guards to push them fully home. (Fig. 2)

Step 6: Fit the Biscuit Joiner back onto the table.

With the power cord disconnected, push in the safety guards and check that the cutter clears the guards and the plastic windows.

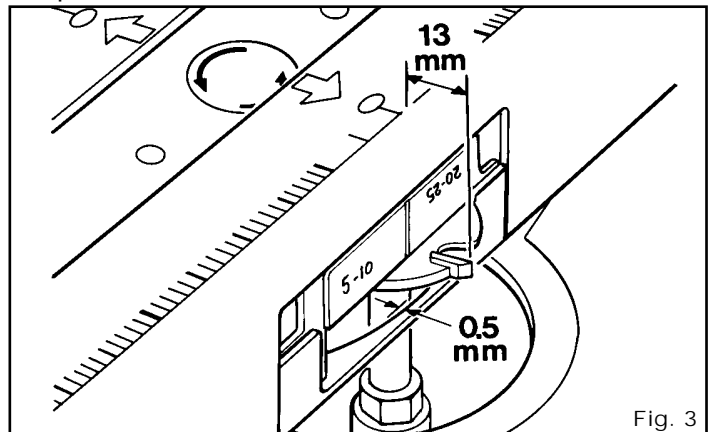

At full extension the cutter should protrude 13mm (1/2") from the face of each window. (Fig. 3) Use a screwdriver to adjust the depth stop screws on the underside of the sliding insert, inward or outward, until 13mm is achieved. (Fig. 4) **In Use:** You can adjust the stops to limit the travel for shallower slots in thin material, using cut down biscuits.

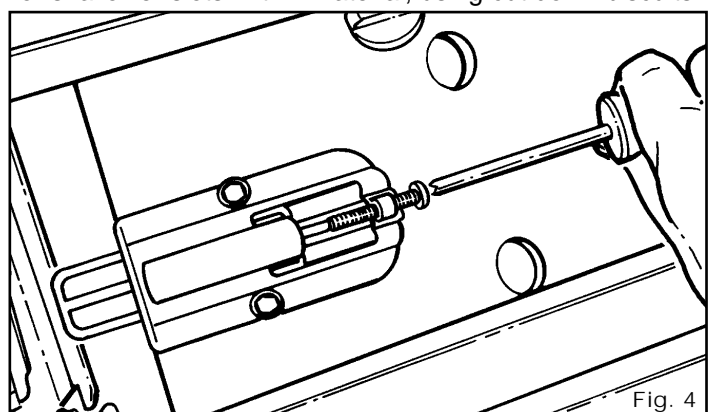

Step 7: Fit the Sliding Guide Clamp (18) to the Sliding Guide (19), using a Coach Bolt (20) & Round Knob (21).

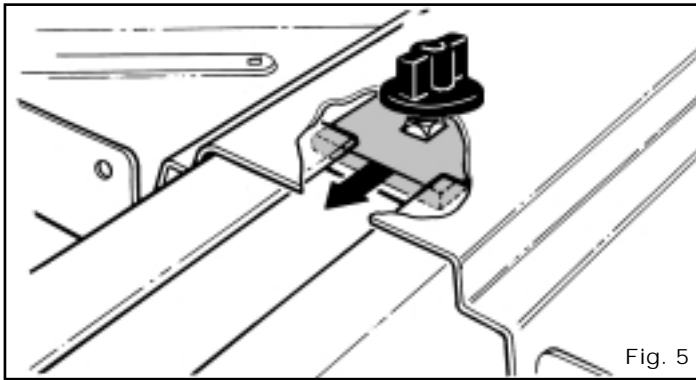

Fig. 5

With the knob loosened, you can slide the guide on and off the main body. Tightening the knob locks the guide to the main body. (Fig. 5)

Dust Extraction

The Biscuit Joiner has been designed for use with a vacuum cleaner for sawdust extraction. It can be used without dust extraction, but you will need to lift the main body after every 20-30 cuts to clean out accumulated shavings.

While any vacuum cleaner can be used, domestic (bag-type) units can fill up very quickly. For a much larger capacity, we recommend fitting a Triton Dust Collector (DCA300) to your vacuum cleaner.

Screw the vacuum hose (left-hand thread), supplied with your Router Table, onto the dust port at the end of the main body and plug the wand of your vacuum cleaner into the hose adaptor.

Power Connection Warning

The combined electrical load of your router and vacuum cleaner may exceed the rated amperage of your domestic extension lead or power outlet. Therefore you should connect your vacuum cleaner and router to separate outlets, and switch on both appliances separately.

Safety

- Always work in a well-lit, uncluttered environment.
- Always wear safety glasses and hearing protection. Use of a dust mask is also recommended.
- Make sure the Router Table is securely locked down to your Workcentre or Router Stand.
- Always switch off the power and/or disconnect the power cord when fitting or adjusting the cutter or raising the main body.
- Always keep hands clear of the cutter apertures in the main body and never operate without the notched or slotted windows in place.
- With the power off, check that the cutter clears the safety guard and windows before making a cut.
- Never push in the safety guards by hand unless the power cord is disconnected.
- Do not join timber narrower than 14mm. The cutter could break through the back of the material.
- Always disable power tools when not in use by switching off the tool and removing the power cord from the Triton switchbox.
- Always keep children and pets out of the workshop, especially when you are operating power tools.

OPERATION

The Triton Biscuit Joiner - BJA300 can be used with or without the sliding guide fitted. The sliding guide can be used on either side of the workpiece and reversed for 45° or 90° joints.

Fig. 6

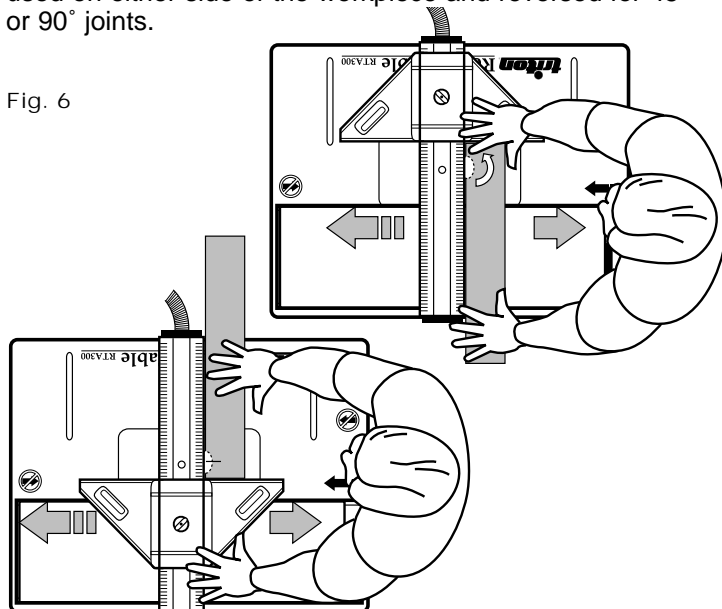

Cutter Height Adjustment

Adjust the height of the cutter above the router plate by using the height adjustment mechanism of your router. It is not normally necessary to exactly centre the cuts on the edge or end of the wood, but make sure you have at least 3mm of material on either side of the biscuit. (Fig. 7) As long as you always lay your wood with the good (or seen) face down on the table, the slots in matching pieces will always line up perfectly. This is especially important if the pieces of wood vary slightly in thickness.

Fig. 7

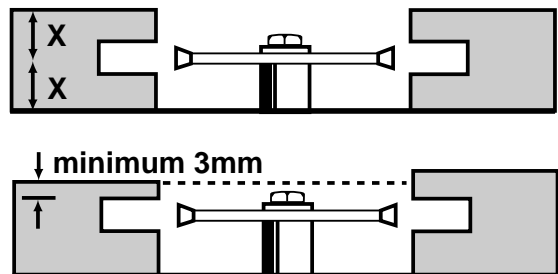

Sighting Up Cuts

If you have marked your wood for the position of the centre of each biscuit, line up your pencil marks with the central lines marked on the windows and the top of the main body. (Fig. 8) You don't have to be very accurate in lining up cuts - the biscuits are designed to move sideways a little in their slots. You can also safely elongate the slots. You use the two reference lines on the top of the main body, on either side of the central line. See "Replacement Biscuits" on page 8.

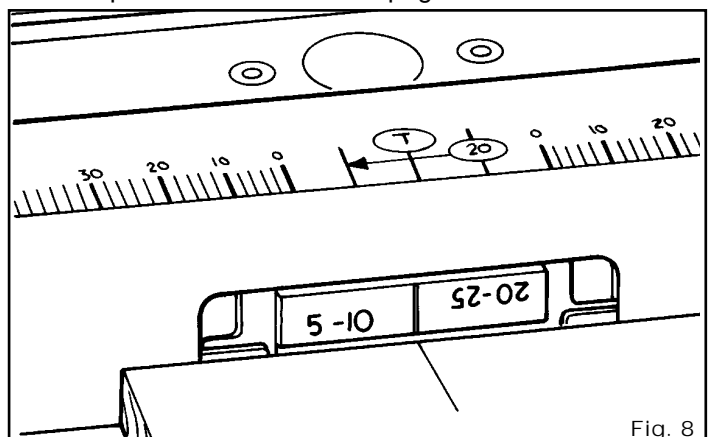
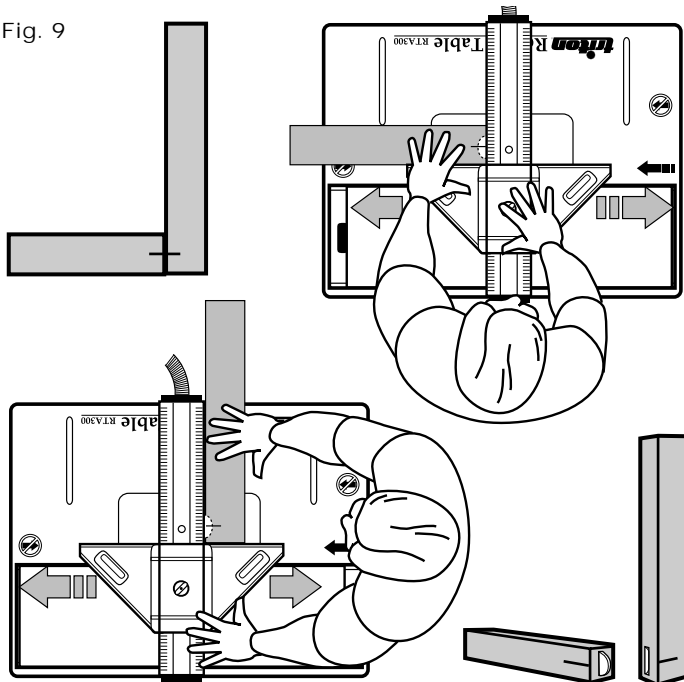

Fig. 8

Right-angle Butt Joint

Place the pieces together in the way you want to join them. Mark the centre-line of the desired biscuit slot. Line up the pencil mark with the central line printed on the main body, and move the sliding guide into position. Lock the guide firmly. Switch on the power, push the safety guard in with the wood, and slide the main body until it hits the depth stop. Allow the main body to return to the centre position. Place the other piece on the other side of the main body, laying it lengthways along the main body, and make the second slot.

Fig. 9



End-to-end Butt Joint

Preview the joint and mark the pieces if desired. Lock the sliding guide in position and cut the first piece using the rear window.

Fig. 10

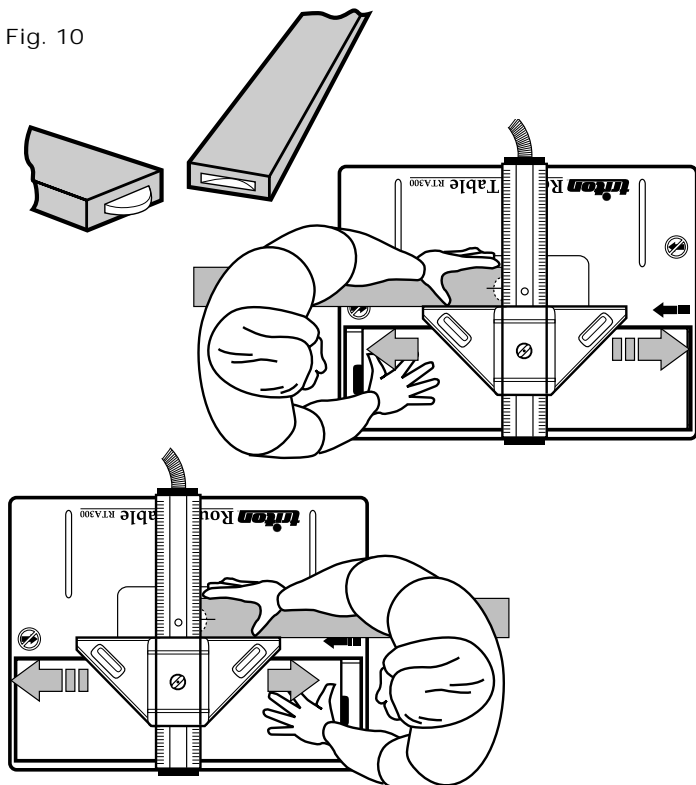

Cut the matching piece at the front window. If your slot is centred on the wood, you can cut both pieces at the same window.

45° Mitre Joint

Reverse the sliding guide and hold one of your mitre-cut pieces against the angled face. With the power switched off, use the wood to press the safety guard in fully. Adjust the position of both the wood and the guide to align your pencil mark with the central line(s) on the main body. Lock the guide in that position.

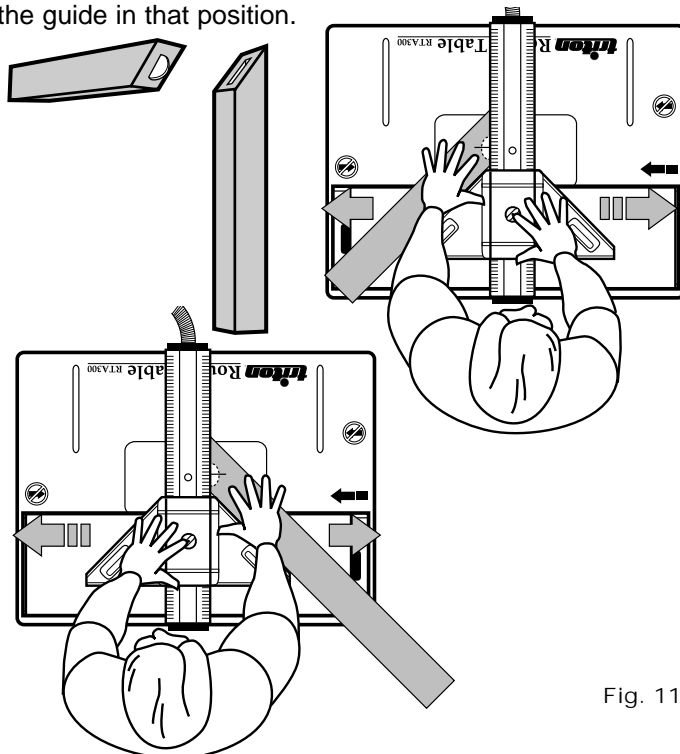

Fig. 11

Use the front and rear windows to cut both pieces. It is possible to make both cuts from the same window if your cutter is exactly central and if the two pieces are exactly the same thickness.

Edge-to-edge Joints

Place the pieces together, good (or seen) faces down, line up the ends, and make pencil marks at the desired spacing.

Fig. 12

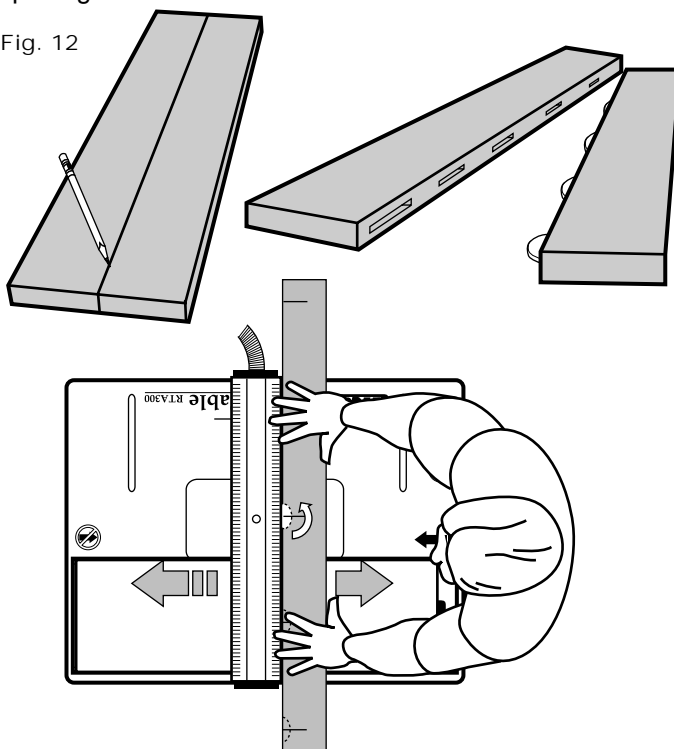

Make the cuts from the front window, holding the wood firmly against the thrust of the cutter. **Hint:** If your wood is slightly bowed, press it down firmly onto the table as you make the cut.

Edge-to-face Panel Joints

Mark the pieces and make the marks on the vertical piece about 50mm long, so that you'll be able to see them. Keep hands well clear of the cutter zone when cutting the vertical piece. The minimum thickness of material for this type of joint is 14mm, unless you are prepared to cut down your biscuits and adjust the limit stops for a shallower slot.

Fig. 13

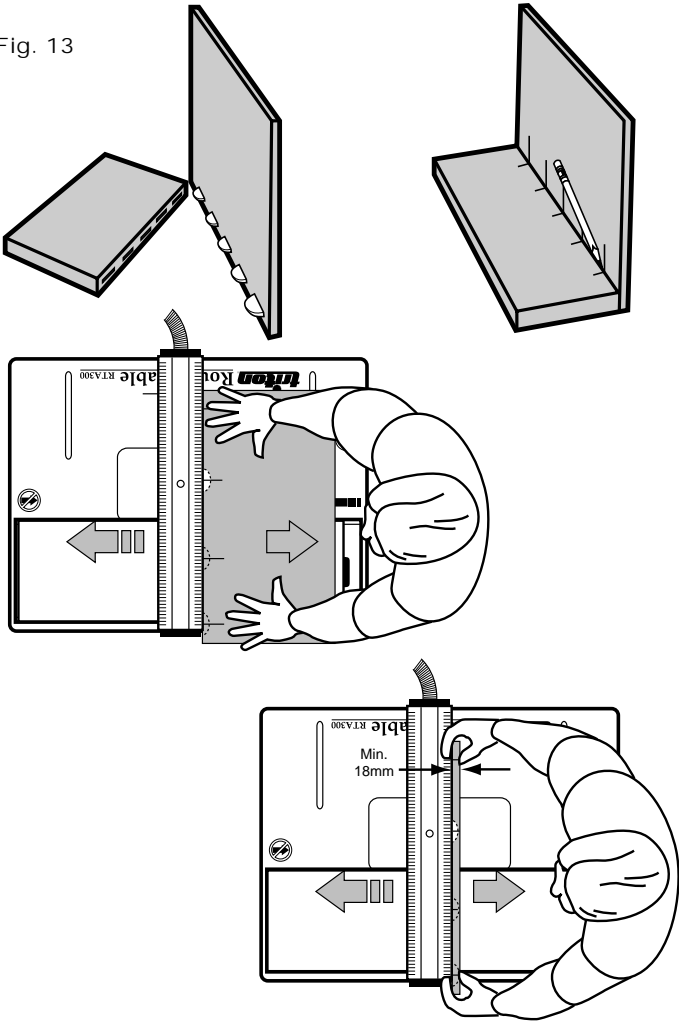

Bevel Joints

Lay out and mark the pieces. Hold the pieces very carefully and steadily against the main body, with the bevel point sitting on the table. Keep hands well clear of the cutter zone, and try not to wobble the wood during the cut or you could create an over-sized slot.

Fig. 14

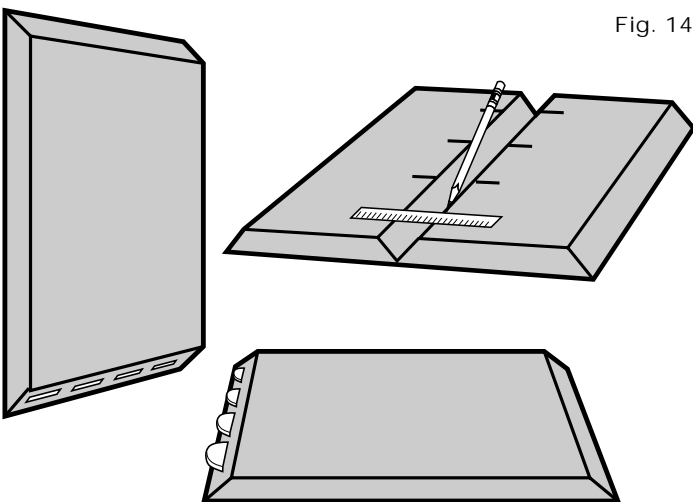
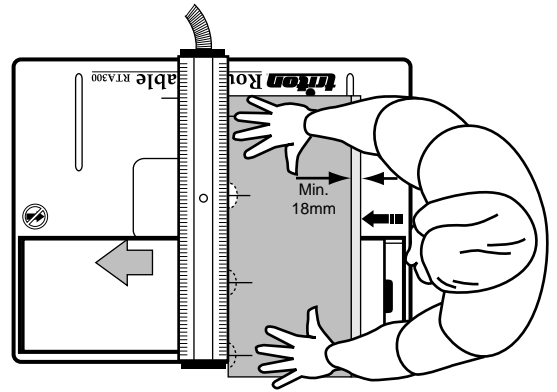
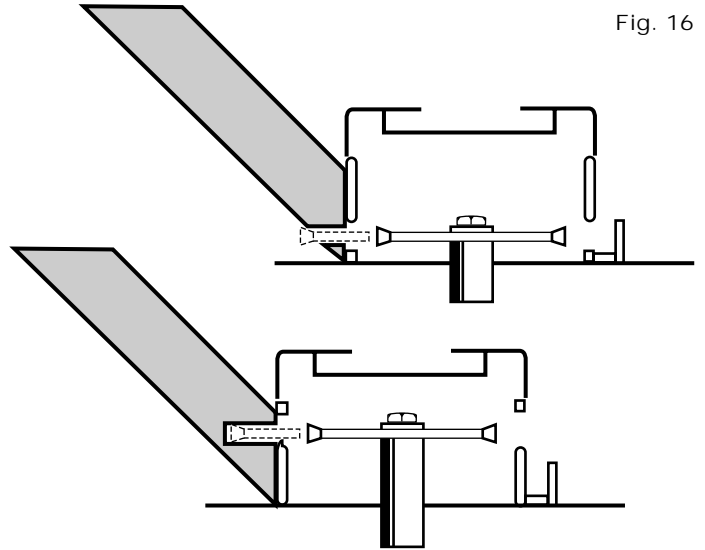

Fig. 15



The minimum thickness of material you can use for bevel jointing with unmodified biscuits is 18mm. The cutter will have to be raised above the centre-line of the bevel to avoid cutter break-out. (Fig. 16)

Fig. 16



Cutting Two-up

After you've had a bit of practice with the biscuit joiner you can cut pieces two at a time provided you use the sliding guide to support the workpieces. Preview the joint with the good (or seen) face up, then turn the pieces over, place them on either side of the main body without changing their orientation, and make two cuts while standing to the side of the table.

Fig. 17

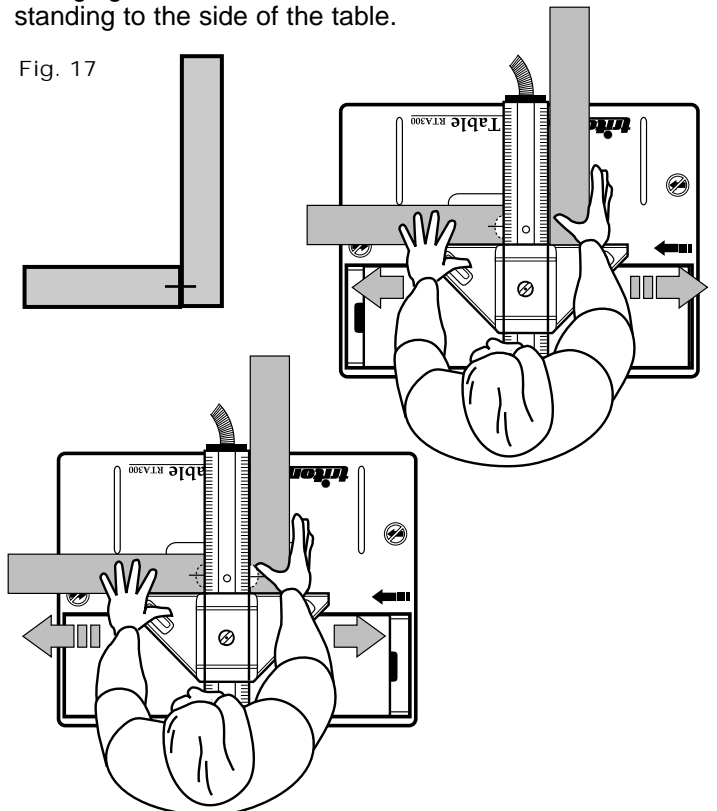

Multiple Biscuit Joints

To improve the strength of certain joints, you may wish to fit several biscuits. Cut the pieces, flipping them from side to side and turning them over after every pair of cuts. Then use the calibration scales on the main body to reset the sliding guide by at least 45mm. Repeat the above two pairs of cuts.

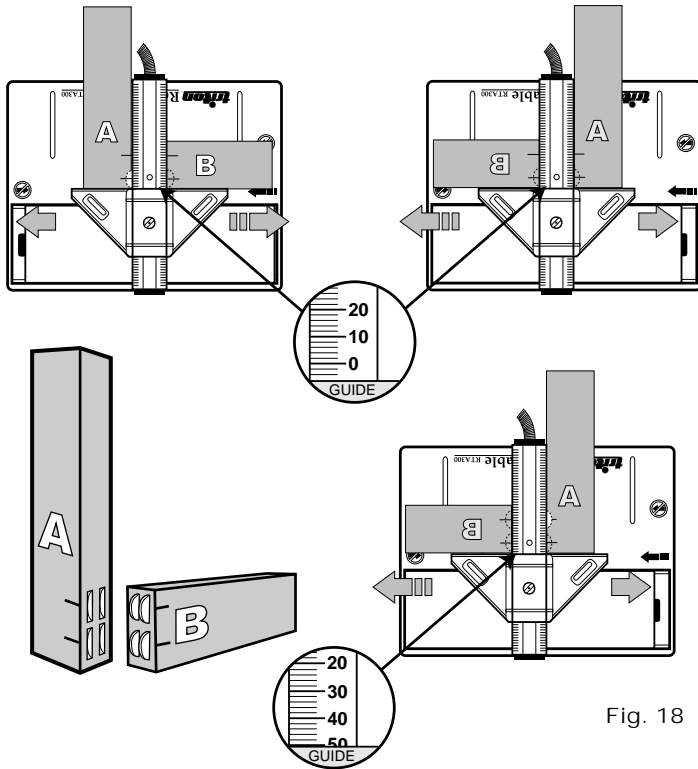
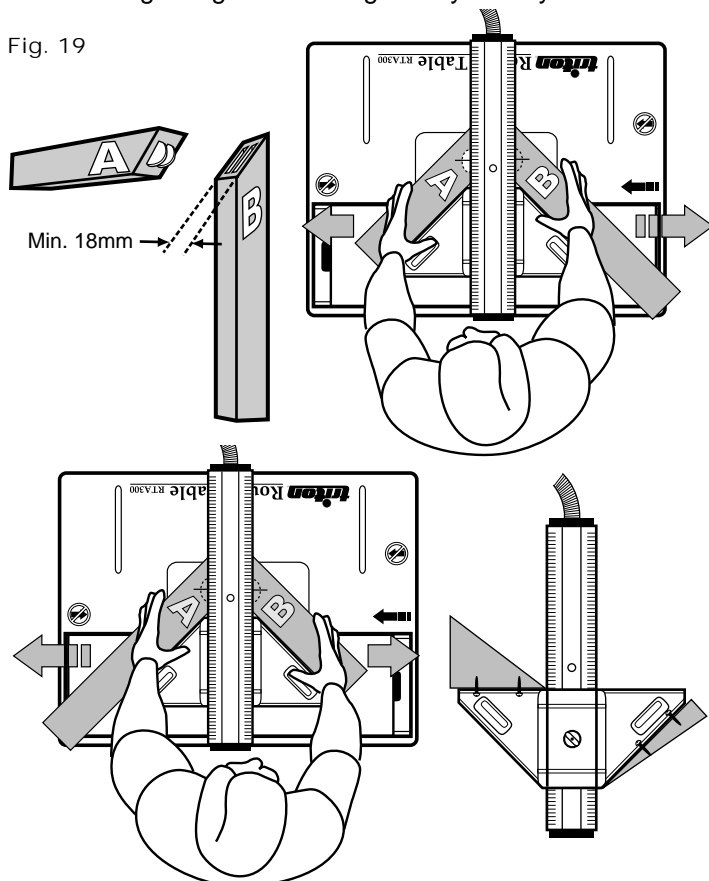

Fig. 18

Provided your material is at least 18mm thick, you can strengthen 45° mitre joints by using two biscuits. To join pieces at angles other than 45° you can still use the sliding guide, if you place appropriately angled wedges between the workpieces and the faces of the sliding guide. Screw-holes are provided in the faces of the guide for attaching wedges or other guides you may make.

Fig. 19



Inset Joints
If you want to create an off-set in a joint, use a packing piece of the appropriate thickness between the workpiece and the table. (Fig. 20)

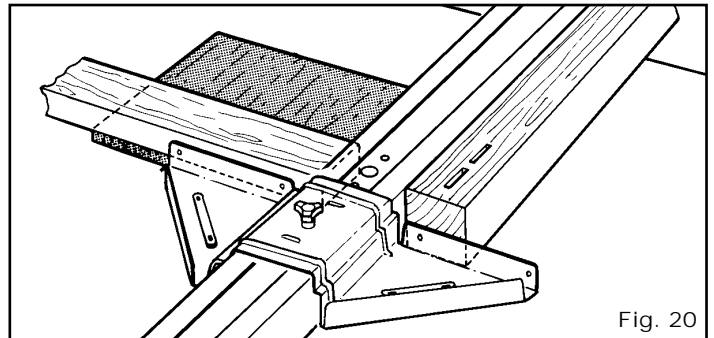
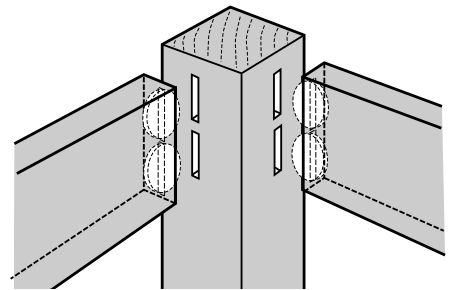

Fig. 20

Make a Work Steady

For handling large pieces held at 45° we strongly suggest you make up a work steady and attach it through the holes in the sliding insert with bolts and large washers. Make the two square sides about 200mm wide with the length being determined by the sort of jobs you'll be doing. Notch out a section of the sides to allow for the cutter and spring-loaded guards. (Fig. 21)

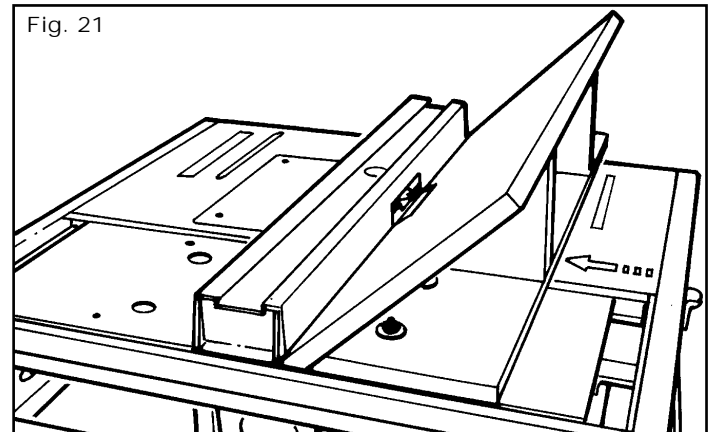

Fig. 21

When dealing with narrow or thin pieces held vertically or at 45°, always use a piece of scrap to push in the safety guard and pivot the main body. Never place fingers in the cutter zone, in case the cutter cuts all the way through the wood. (Fig. 22)

If you want to join narrow pieces, position the sliding guide so that the slots extend beyond the face you are joining. Glue and assemble the joint, and when the glue has dried, carefully trim off the protruding end of the biscuit. The contrasting colour can look quite effective.

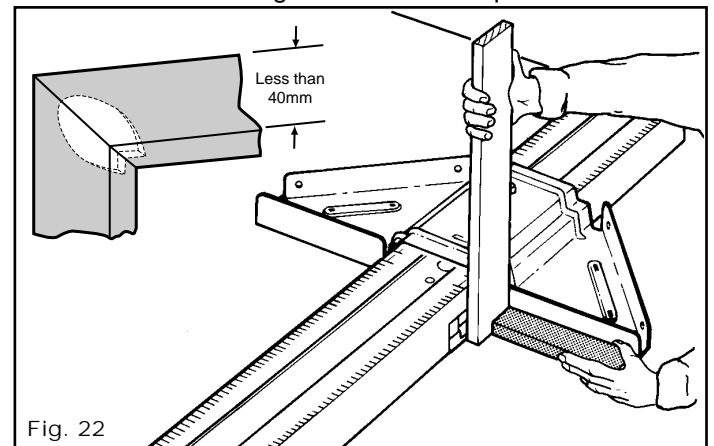
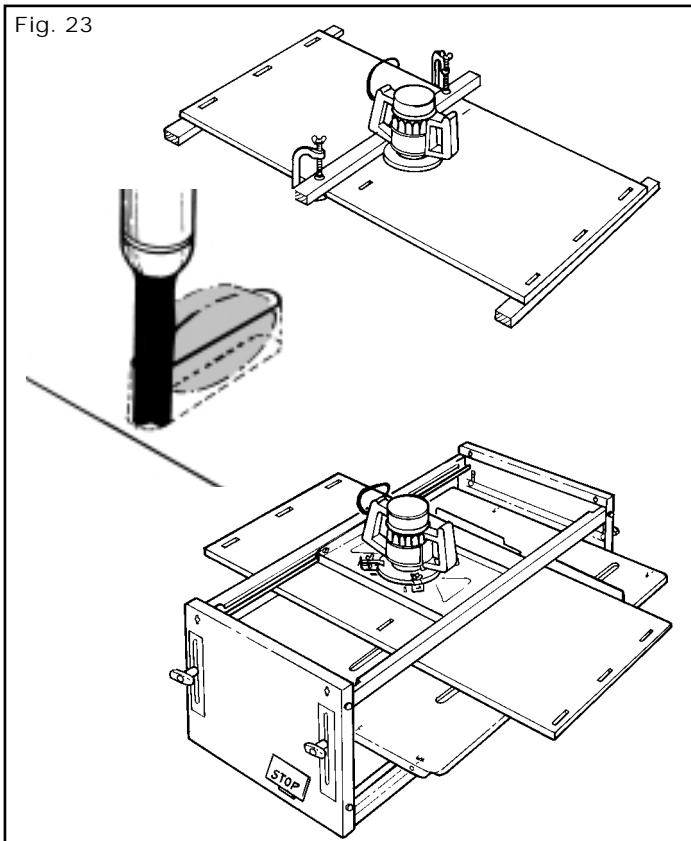

Fig. 22

Mid-panel Joinery

The Biscuit Joiner cannot be used for cutting slots more than 25mm from an end or an edge of a panel. For certain jobs (eg. sides of a bookcase or cabinet), consider using another method of fixing shelves or dividers, such as screws, rebated trenches, cleats or dowels.



If you prefer to use biscuits throughout you can purchase from Triton a straight carbide cutter with a 4mm cut width (part no. BJA045).

This cutter can be used for cutting mid-panel slots using the router hand-held against a clamped batten. Alternatively it can be done in the overhead mode on your Workcentre using the optional Router Mounting Plate (AJA150).

With a plunge router, and some practice, you can produce slots with a curved bottom. However flat-bottomed slots 13mm deep by 40mm long are acceptable, and much easier.

Biscuit Spacing

The number of biscuits required for particular joints will depend on the type of material being joined and the loads which the joint has to carry. As a rule of thumb, use one biscuit (or row of biscuits) in material up to 20mm thick, and two biscuits (or rows) in thicker materials, spaced equally about 1/3rd the way in from either face.

The spacing between the biscuits along edge-to-face panel joints and bevel joints should be around 150-200mm. For long edge-to-edge joints, such as for a table-top in natural timber, around 300mm between biscuits is generally adequate.

Test Assembly

Test assemble your work before applying the glue to check alignment and fit. Because the biscuits can move lengthways in their slots, you can usually true up joints easily.

The glue faces and the slots should be clean and dry prior to gluing. Remove any sawdust or shavings by brushing or blowing.

REPLACEMENT BISCUITS

Triton biscuits are specially shaped to suit the cutter supplied. Replacement Triton biscuits are available from your Triton stockist in packs of 50 (BJA050), or 500 (BJA056).

You can use other brands of biscuits, but they are a different size. These biscuits, commonly called #10 and #20 biscuits, require elongated slots. Use the reference lines printed on top of the main body on either side of the central line. Start at the line marked "20" and move the wood towards the outside line, in the direction of the arrow.

The #10 biscuit slots require the depth stops to be adjusted to reduce the travel of the sliding insert.

GLUES AND GLUE APPLICATION

Good quality water-based adhesives, such as PVA glues, are the most suitable for biscuit joining because they have good quality wetting properties, and the moisture makes the biscuits swell up evenly to tighten the joint. Epoxy and resorcinol-type adhesives can be used, but we do not recommend the use of highly viscous glues such as construction adhesives.

Triton brand Premium Woodworking Adhesive offers superior bond strength and better sanding and staining characteristics than most commonly available PVA glues. Available in 250ml, 500ml and 2.5 litre bottles.

Apply the glue sensibly. It is unnecessary and wasteful to fill the slots with glue. On the other hand you need enough glue to fully "wet-out" the sides of the biscuits. Coat the biscuits with glue and/or paint glue on the walls of the slots, using a thin spatula, a cotton bud, or a small paint brush (a #6 artists size is ideal).

The best way to tell if you're using the right amount of glue is when you clamp the joint. A fine line of glue should be squeezed out. Glue liberally dripping out indicates an excess, and no glue visible means a starved joint.

CARE OF THE CUTTER

Inspect the cutter teeth regularly for chips or bluntness, and remove accumulated resins from the tips. Have the cutter professionally sharpened when blunt. When not fitted to your router the cutter should be stored in its special housing at the end of the main body to prevent accidental tooth chipping.

Replacement cutters (BJA038) or cutting discs (BJA039) can be ordered through your Triton stockist

Due to our company policy of continuous product improvement, specifications may change without prior notice.

Made in Australia by: Triton Manufacturing & Design Co. Pty. Ltd. ACN 000 195 951 ABN 43 000 195 951
14-18 Mills St, Cheltenham, Vic. 3192 Ph: (03) 9584 6977 Fax: (03) 9584 5510
E-mail: tools@triton.net.au Web Site: http://triton.net.au

International Offices:

Canada - Toll Free: 1 888 874 8661

Japan - Free Call: 0120 171 079

New Zealand - Ph: (09) 415 2545

South Africa - Free Call: 0800 600 432

United Kingdom - Free Call: 0800 856 7600

USA - Toll Free: 1 888 874 8661